



The Urinal Shop

INSTALLATION INSTRUCTIONS

URINAL FLUSH VALVE

ET3-R

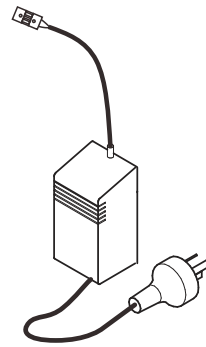
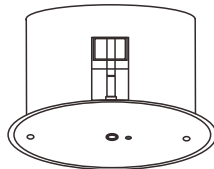
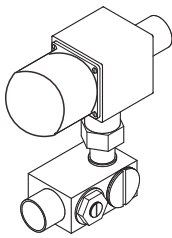

Thank you for purchasing this Enviro-Tech product



INSTALLATION INSTRUCTIONS ET3-R URINAL FLUSH VALVE

We strongly recommend that you use a qualified and registered plumber and electrician. You must ensure all pipe work is flushed adequately, particularly in new builds or where lines have been disrupted. Components of sensor products are particularly susceptible to debris and will require more thorough flushing than a standard plumbing fixture.

TECHNICAL SPECIFICATION

Function	ET3-R
Power Input	AC220-240V (50/60 Hz)
Power Consumption	900mA
Water Pressure	100kPa-500kPa (recommended 350kPa)
Inlet/outlet Diameter	15mm 1/2G
Detection Zone	1600X1000mm (adjustable)
Inductive Confirmation Times	6 times within 5 seconds
Confirmation Time after Use	5 seconds
Flush Time	4 seconds (adjustable)
Reset Time after Flush	20 seconds
Trap Seal Protection	Automatic flush every 6hrs if not used
Flush Delay Time	After user leaves: 30 seconds

COMPONENTS

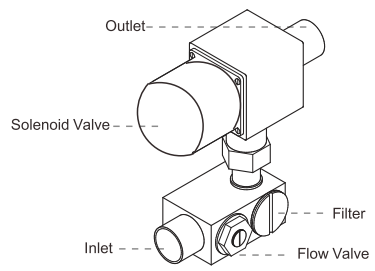

1. Solenoid Valve

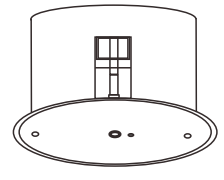

2. Sensor

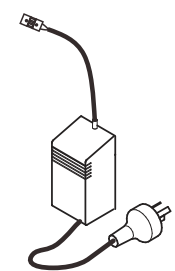

3. Transformer

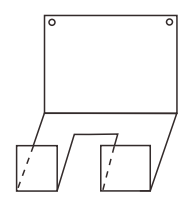

4. Bracket

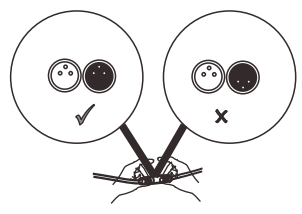
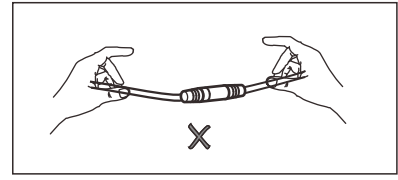
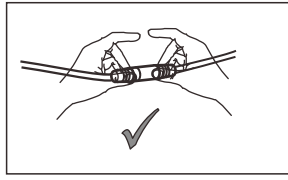

Attention:
Hold the plug not the wire to connect and disconnect and make sure the pins align to the holes in the right position.

SOLENOID VALVE INSTALLATION

- > Flush pipework thoroughly - failure to do so will result in the solenoid sticking soon after install, which is not covered by your product warranty.
- > Attach bracket then fix solenoid valve into it.
- > Connect water feed to inlet valve.
- > Connect outlet to urinal.

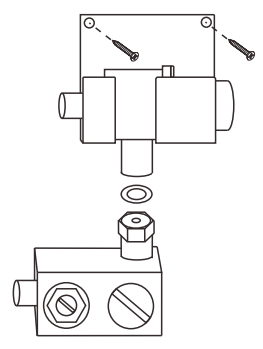

SENSOR INSTALLATION

Note: Ceiling must be level, if ceiling is sloping/pitched the detection zone will be altered.

Single Urinal

1. Drill a 70mm hole in the ceiling centred on the urinal and 100mm from the wall/back of urinal to the centre of the sensor.

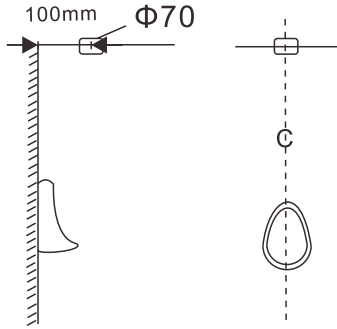

Twin or Trough Urinals

1. Drill a 70mm hole in the ceiling centred on the trough or the two individual urinals and 300mm from the wall/back of urinal to the centre of sensor.

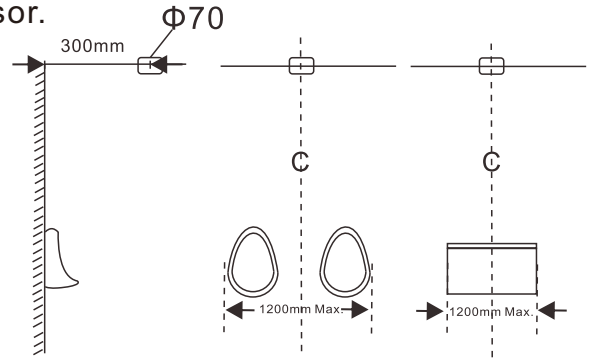

2. Remove the screws from the sensor plate and install the flush box into the ceiling using the screw clips. (Ensure the sensor screw holes are aligned as shown in 3)

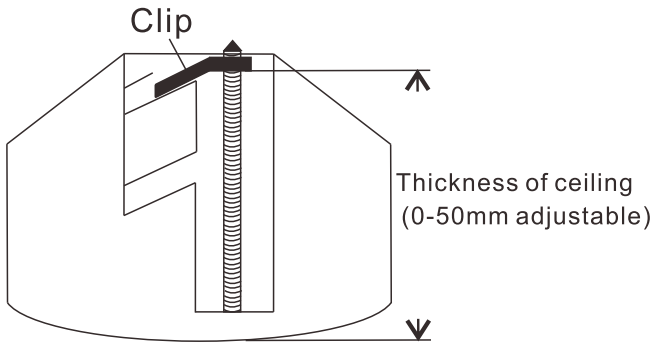

2. Remove the screws from the sensor plate and install the flush box into the ceiling using the screw clips. (Ensure the sensor screw holes are aligned as shown in 3)

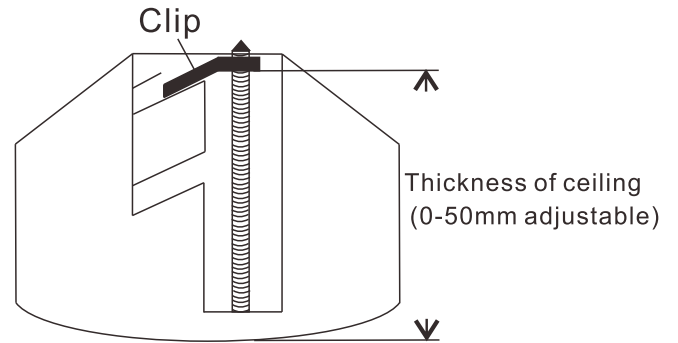

3. Single urinal: refix the sensor plate using the 2 screws, **ensure sensor plate screws are parallel to wall for the single urinal.** (Before refixing make any changes if required to flush time or preflush settings, refer to page 4 and 5)

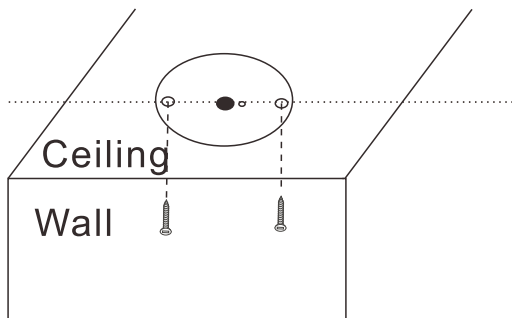

3. Twin or Trough urinals: refix the sensor plate using the 2 screws, **ensure sensor plate screws are aligned facing the wall.** (Before refixing make any changes if required to flush time or preflush settings, refer to page 4 and 5)

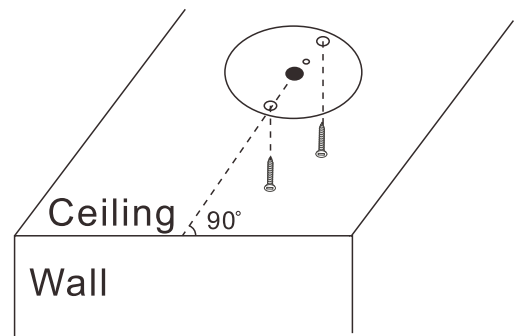

4. Connect solenoid valve to sensor (black plugs) and connect sensor to transformer (white plugs). Connect to power only when installation is complete, system will then run test and be ready to use.

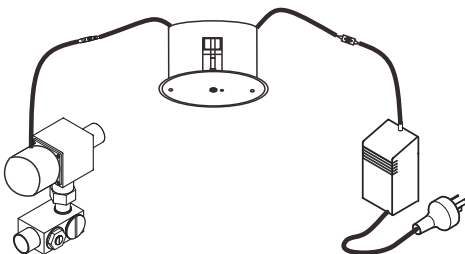

4. Connect solenoid valve to sensor (black plugs) and connect sensor to transformer (white plugs). Connect to power only when installation is complete, system will then run test and be ready to use.

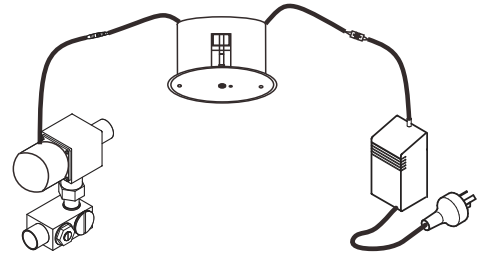

SETTINGS

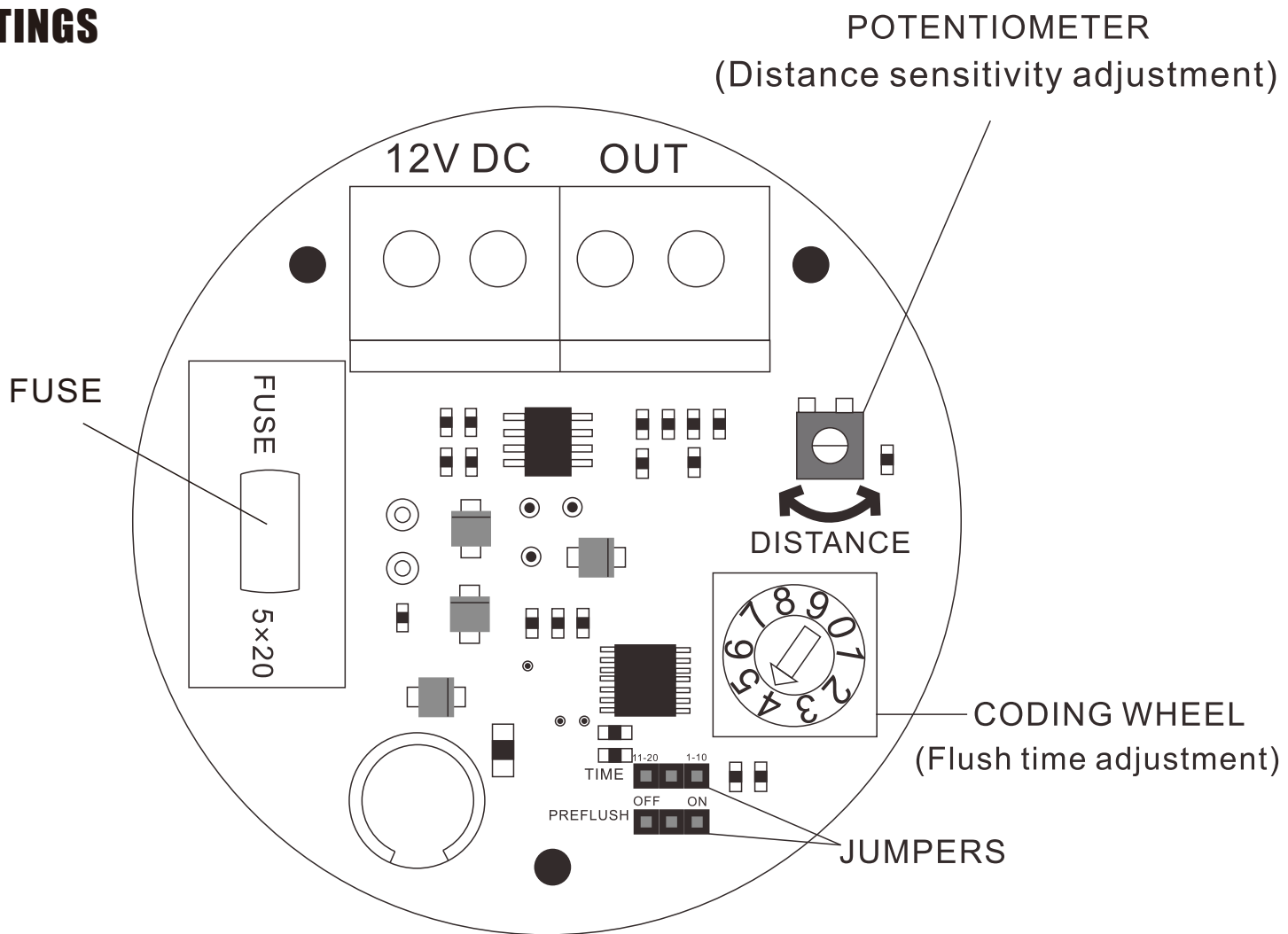

DISTANCE

Turn the potentiometer clockwise to increase the sensing distance and anti-clockwise to decrease it.

PREFLUSH

Preflush on/off

Set the jumper to left (OFF) to turn off the preflush and set the jumper to right (ON) to turn on the preflush.

The factory setting is right (ON).

FULL FLUSH TIME

Set the jumper to left to choose 11-20s (20s=0s) and right to choose 1-10s (10s=0s) adjusting range.

Set the coding wheel to required flush time.

(Factory setting is: Preflush "ON", time "4" and "1-10 Jumper right" at 350kPa, giving a flush volume of 0.8ltr for a single urinal)

FLUSH VOLUME SETTINGS

Time settings for flush volumes without "Preflush"			
Urinal Type	Dynamic Pressure	Time Setting	Flush Volume
Single Urinal	350kPa	6s	0.8L
	500kPa	5s	
Twin Urinal	350kPa	12s	1.6L
	450kPa	11s	
	550kPa	10s (10=0)	
Slab/Trough Urinal	350kPa	19s	2.4L
	400kPa	17s	
	450kPa	16s	
	500kPa	15s	
Time settings for flush volumes with "Preflush"			
Urinal Type	Dynamic Pressure	Time Setting	Flush Volume
Single Urinal	350kPa	4s	0.8L
	500kPa	3s	
Twin Urinal	350kPa	8s	1.6L
	450kPa	7s	
	550kPa	6s	
Slab/Trough Urinal	350kPa	12s	2.4L
	400kPa	11s	
	500kPa	10s (10=0)	

DETECTION ZONE (GUIDE ONLY)

2.4 M Height Installation

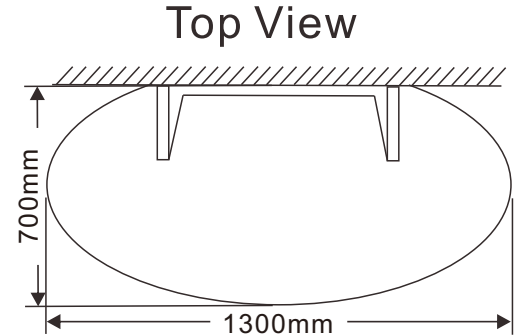
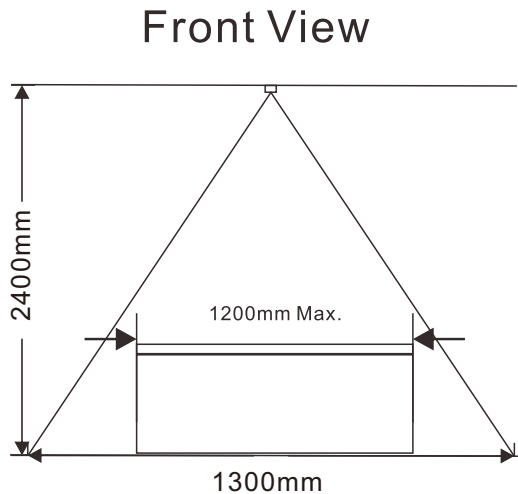
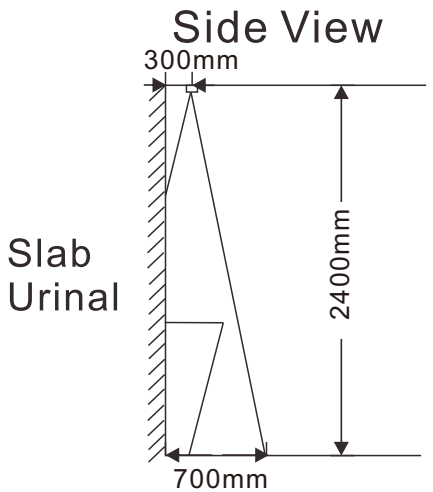
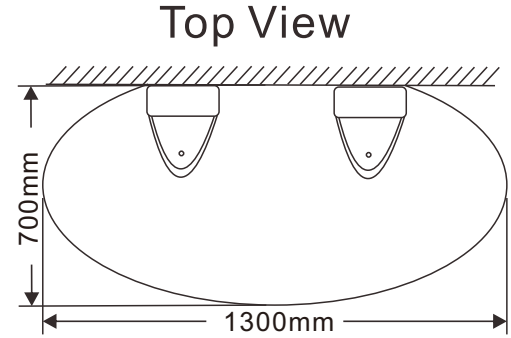
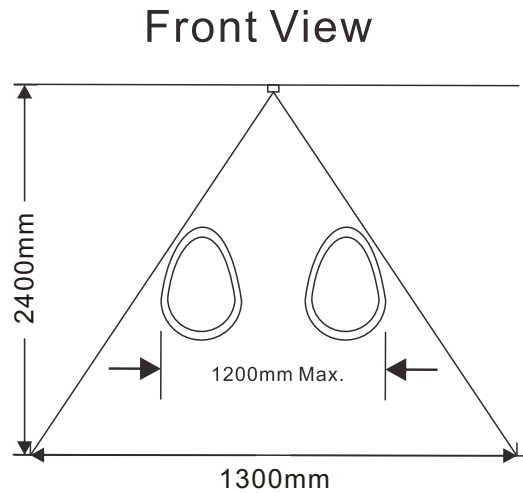
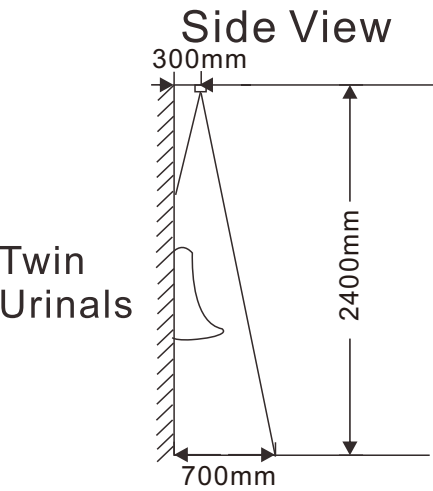
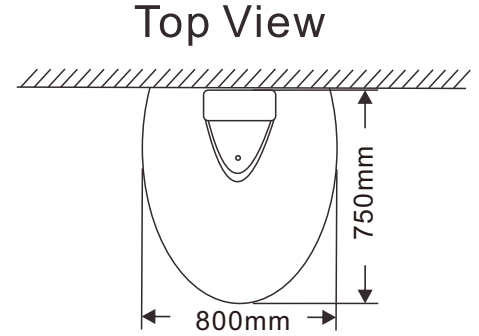
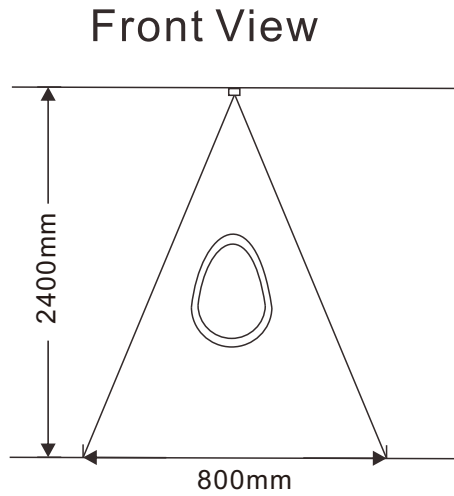
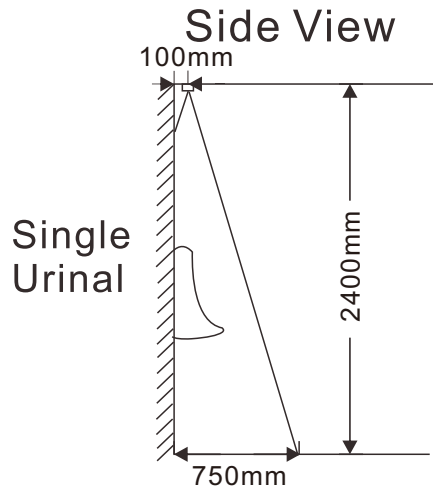

DETECTION ZONE (GUIDE ONLY)

3 M Height Installation

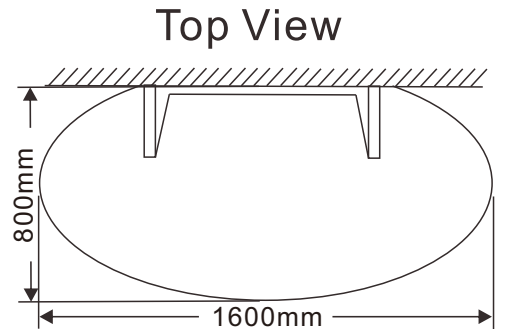
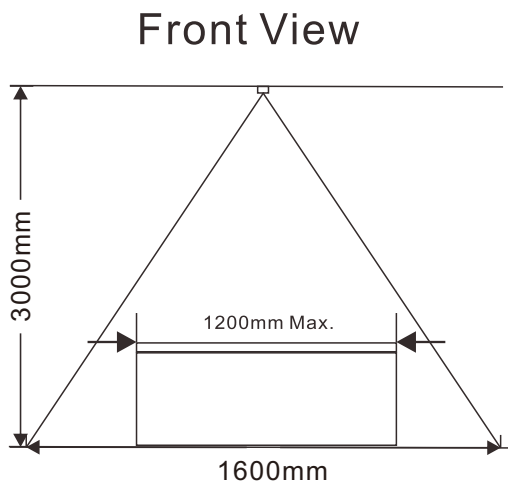
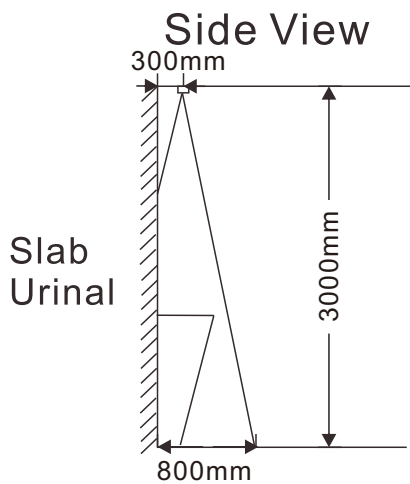
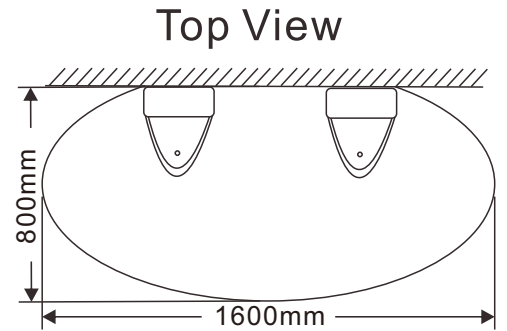
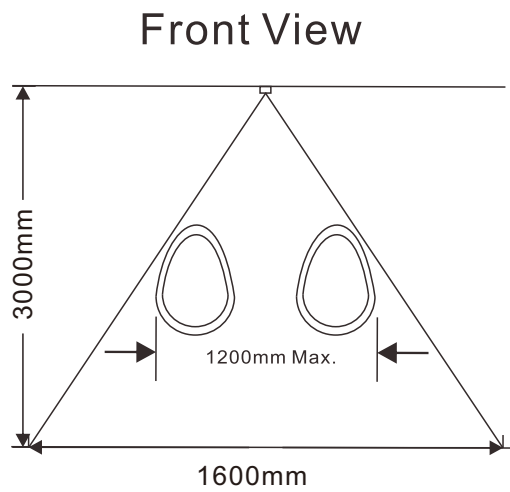
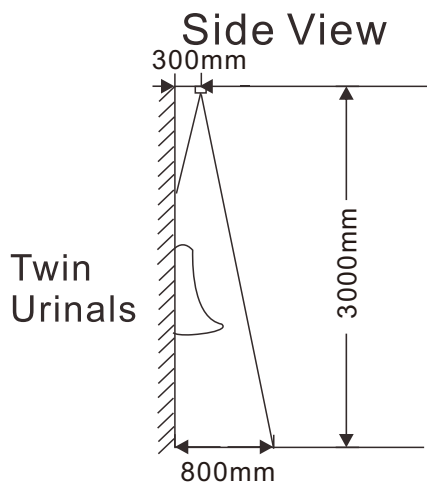
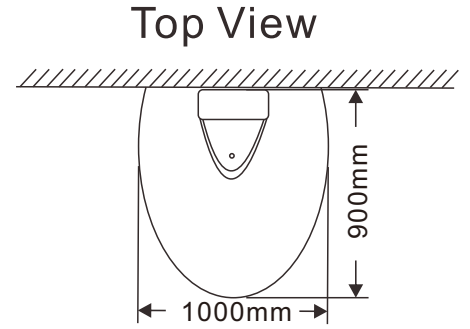
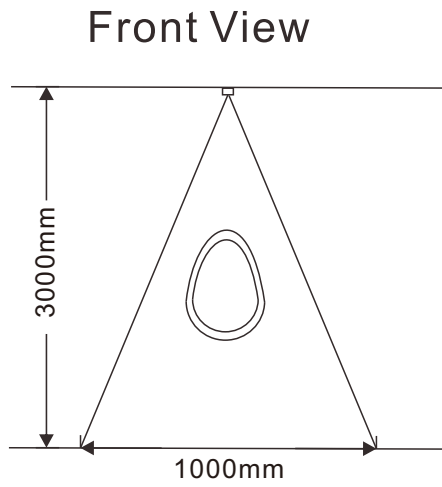
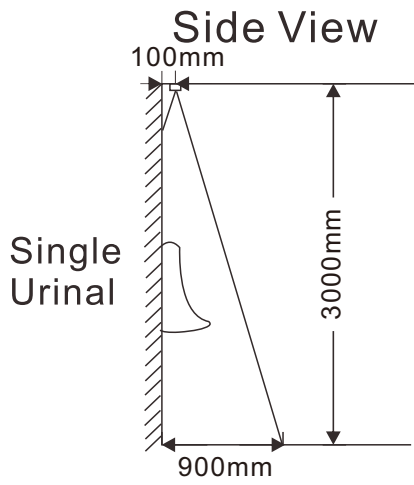

TROUBLE SHOOTING

Problem	Possible Cause	Solution
No water out/ will not stop running	<u>Most common:</u> Plugs not connected correctly/No water supply/ No power The filter or solenoid is blocked	•Check water and power supply. •Unplug all cables, leave unplugged for 5 minutes and reconnect everything carefully. Clean Filter. Clean/replace solenoid.
Too little water flow	Water pressure is low or turned down. Flow valve needs adjusting The filter or solenoid is blocked	Adjust/raise the pressure. Adjust flow valve on solenoid. Clean the filter. Clean/replace solenoid.
Too much water flow	Water pressure is too high Flow valve needs adjusting	Adjust pressure Adjust flow valve on solenoid
Flush time/sensing distance not adequate	Sensor requires adjustment	See the 'Settings' section of this manual for instructions



WARRANTY

This Enviro-Tech product is guaranteed for 12 months from the date of purchase. This is a parts only warranty and Enviro-Tech is not liable for any associated costs incurred in the replacement or repair of any item. For full details of the warranty conditions, see the Warranty page of our websites.

AFTERCARE

Ensure good water quality is maintained and the filter on the solenoid valve is cleaned out regularly. Failure to do so could result in a blocked solenoid/impair product functionality and may invalidate your product warranty. Surfaces should be maintained using a clean damp cloth, no abrasive agents or materials should be used or come into contact with the surface finish, or this will invalidate your warranty.

This Enviro-Tech product is manufactured strictly to adhere to the ISO9001 standard, WaterMark certification and WELS standards. Enviro-tech reserves the right to update product technology at any time.

Sydney - Head Office
1800 URINAL (874625)
(02) 9863 0968
info@theurinalshop.com.au