

BORONIA

WATERFREE URINAL
VITREOUS CHINA



Falcon Waterfree urinals reduce water and sewer costs, maintenance and repair bills, and create more hygienic, odour-free restrooms. A patented, sealed cartridge eliminates the need for water, conserving an average of 236,000 liters per urinal each year.

With waterfree urinals, water does not have to be pumped to or from the urinal. This saves energy, which in turn reduces carbon dioxide emissions associated with energy production - emissions that would otherwise contribute to global warming.

Purchasing and installing Falcon Waterfree urinals is less expensive than manual and automatic flush units because flush valves and associated piping are not required. Maintenance costs and vandalism problems associated with flush valves are also eliminated.

FEATURES

BENEFITS

- | | |
|--------------------------------------|--|
| • Touch-free operation | • Improved hygiene and safety |
| • Uses no water | • Reduced water and sewer costs |
| • Mechanical-free design | • No costly flush valve or sensor repairs |
| • Patented, sealed locking cartridge | • Odour-free and vandal proof |
| • Maintenance-free cartridge | • No need to replenish sealant between changes |
| • Smooth, non-porous surfaces | • Minimal care and easy cleaning |
| • Vitreous china bowl | • Unsurpassed durability |

Used in conjunction with our High Performance Key-Valve (HPKV), the most robust, high performance dry valve in the market. Through our patent-pending Bell Valve our HPKV technology provides safe, long lasting, low odor performance.



The Urinal Shop

THE URINAL SHOP

1800 874 625

theurinalshop.com.au

info@theurinalshop.com.au

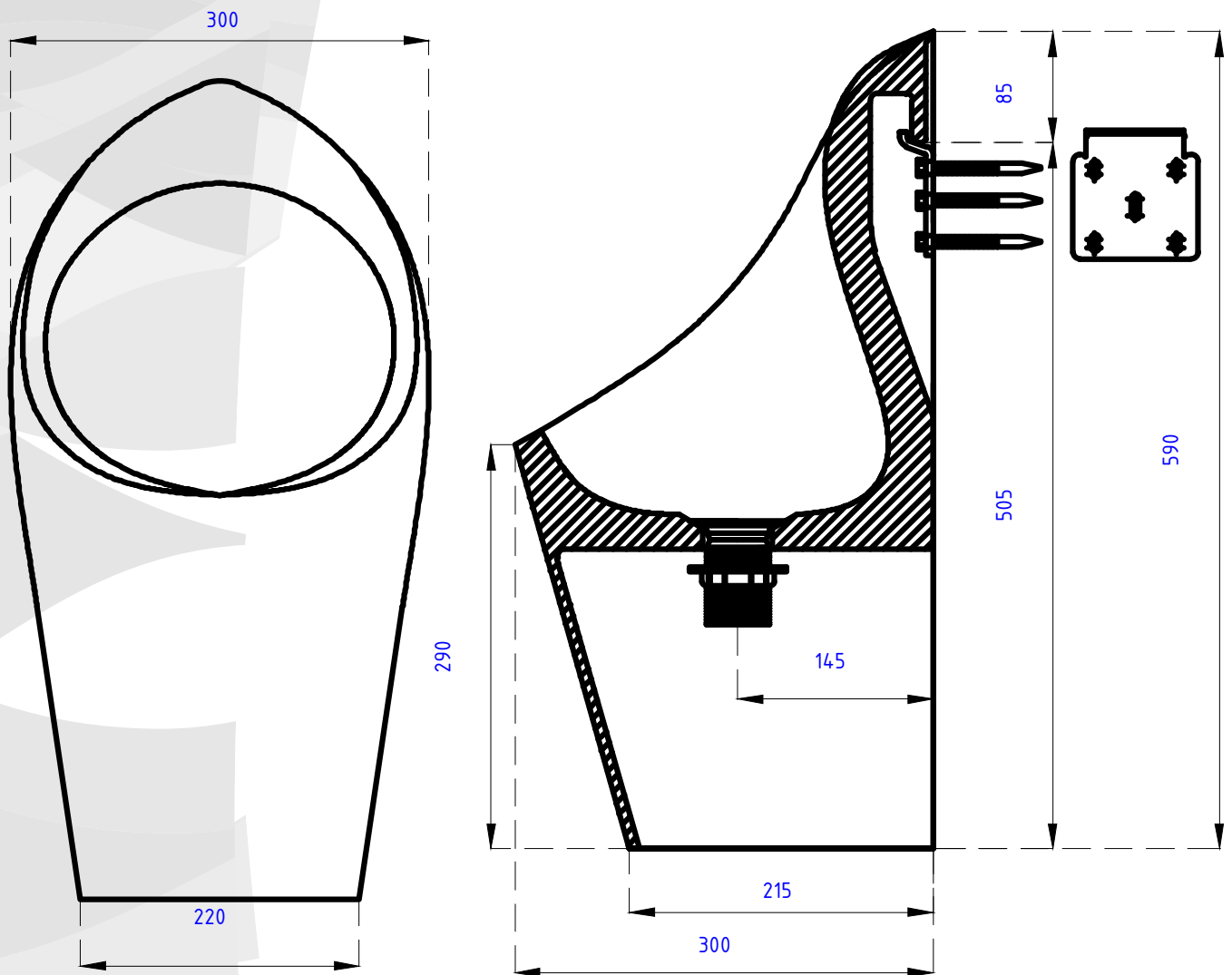

These dimensions are for informational purposes only. For specific rough-in dimensions, please refer to specification sheets available on our web site or contact us directly.



Installation Details

Please use 50mm PVC drain pipe

A 50mm Kee Seal and Screwed Elbow is provided to link the urinal to the drain pipe.

Urinal mounting height is approx 600mm from the floor to the front lip of the urinal.

The 50mm drain pipe should be installed 430mm from the floor to the centre of the pipe.