

# caroma®

CI/SfB	(74.1)	g3
Date	July 2008	

Supersedes all previous issues

## Torres Invisi II Urinal Suite

# 7.04.1

Vitreous China Wall-Hung  
Urinal with Invisi II Cistern for  
Inwall, Induct or Inceiling applications

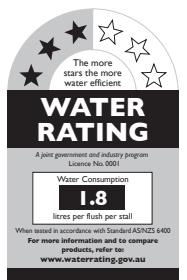

Available November 2008

# Torres Invisi II Urinal Suite

Vitreous China Wall-Hung Urinal with Invisi II Cistern for Inwall, Induct or Inceiling applications



A general application wall hung urinal with integral trap. An adjustable spreader is suitable for installations with increased cistern head height. The spreader channels water to the front and back areas providing a wash down of the bowl on each flush. Available with back inlet and with a stainless steel grate as standard. Concealed cistern and plumbing fittings provide space saving, ease of cleaning and performance matched components to maximise low volume flushing efficiency.

**Torres Invisi II** urinal suite Code No.742100W.

- Inlet:** Standard with back inlet for concealed pipes with 20mm O.D. inlet for connection with capillary or compression fittings.
- Outlet:** Two rubber connection seals are supplied for a push-on fit with 50mm O.D. brass tube and 50mm DWV plastic pipe.
- Cistern:** **Invisi II Cistern** – suitable for inwall, induct and inceiling applications. Achieves a 3 star water efficiency rating when installed as a single stall urinal. Buttons are supplied separately, see page 6.15.1 for button and panel options. For inwall applications a blank access panel and remote single flush button are required (not supplied). For induct or inceiling applications where access is available to the cistern and button either the remote or custom buttons are suitable (not supplied).
- Fixing:** **Urinal** is fixed to the wall with – **D.232 Concealed support bracket**; cast aluminium natural finish supplied with cadmium plated locating bolts and fasteners. **Cistern** is simply mounted into position by clipping onto the two quick clip mounting brackets which are secured with screws to the studwork or induct brickwork. Cistern brackets supplied.
- Colours:** White only.
- Dimensions:** All dimensions are in millimetres and are subject to normal manufacturing variations. Caroma pursues a policy of continuing improvement in design and performance of its products. The right is therefore reserved to vary specifications without notice.

## Torres Invisi II Urinal Inwall/Induct Installation

### Inwall Urinal Suite

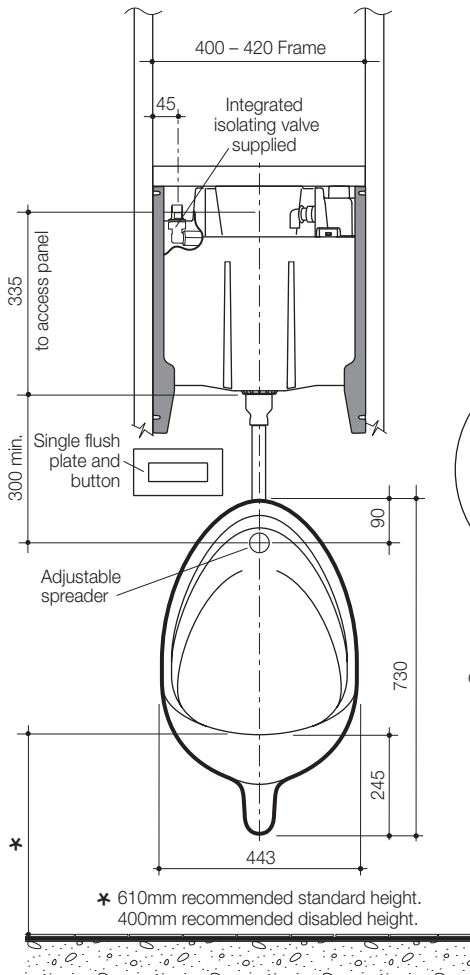

### Induct Urinal Suite

