

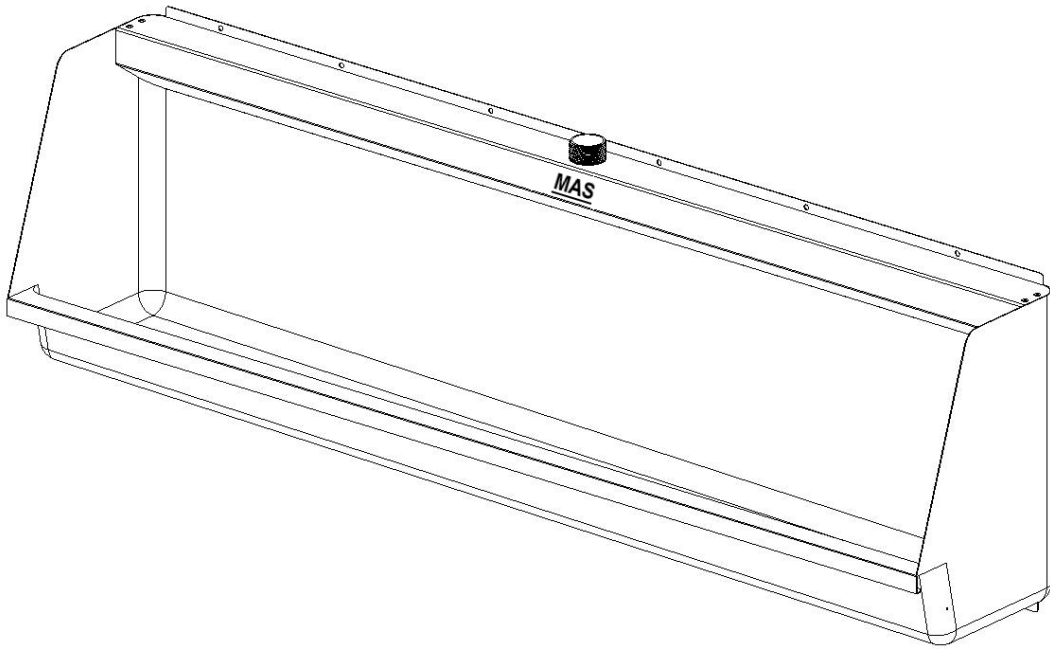

Wall Hung Multi Stall Urinal

Installation Guide



Important

All installations and services must be carried out by a licenced plumber in accordance with the plumbing code of Australia AS/NZS 3500.2
And installed to the appropriate standards in conjunction with local state or territory requirements

All MAS urinal are manufactured to exceed industry standards and performance made from 1.2mm thick 304 grade stainless steel under strict controlled conditions

All MAS multi stall urinals have a 40mm MI inlet and sparge nut with tapered washer to suit a 38mm O.D MAS sparge pipe **SP5** or **SP5A**

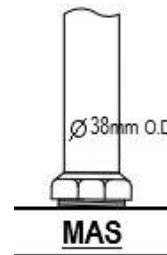

All MAS urinal are supplied with a Watermarked stainless steel domed urinal grate for the outlet code: **SP4**

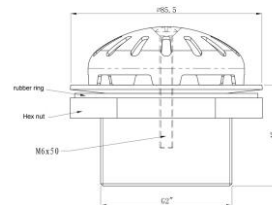

Any discrepancies or damages in supply must be reported to MAS within seven (7) days of invoice by phone or email
No claims will be considered unless reported within specified time
Phone : 07 3890 8011 Email : sales@masales.com.au

Installation

- Before installation ensure the substructure has been prepared to accommodate all necessary services for supply and discharge. Please refer to attached diagram for the MAS urinal model requirements. Ensure the substrate is clean and plumb, all walling must be perfectly flat and square for installation.
- Determine the height of the MAS urinal to be installed by the situation and venue, keeping in mind finished floor height . Generally, 610mm for adults and 510mm for juniors measured from the front lower edge of the urinal rim. Heights are suggestions only and should be in accordance with suitability of intended users and as per the governing authorities' regulations.
- Mark a horizontal line 335mm above the intended installation height of the urinals lower rim edge. (i.e. 610mm lower edge + 335mm top of urinal) This will give you the top finished height of the urinal. The fixing holes on the top edge of the urinal will be 15mm below the top finished height. Mark a vertical line intersecting the horizontal line at the intended centre of the urinal being installed, see necessary line drawings.
- Complete the rough in of all necessary services for inlet and outlet, ensuring there is adequate space for lower fixing points on the urinal. All MAS Multi stall urinals are left hand outlet and have a positive fall towards the drainage outlet, be sure to allow for this during the rough in.
- Ensure the walling is adequate to support the weight of the specific model, in severe failure of the outlet a significant water weight will be held in the trough of the urinal, be sure to allow for this. Ensure the fixings screws of the urinal will meet up with studs, if not fit noggins as needed in both the top and bottom fixing points. Please see individual drawings for fixing hole positions.
- Once ready for fitting, position the urinal to the centre vertical line and horizontal line. Fit one of the anchor points towards the centre of the urinal. Place a spirit level on the top surface of the urinal and then adjust the urinal into a true level and tighten the fixing anchor to hold the urinal in place. Install a second fixing anchor then check for level once again.
- Fit the remaining anchor fixing points from the inside working your way out ensuring to check for level as you go. Ensure the urinal sits flush against the wall surface and then install fixing anchors to the lower fixing points of the urinal. All fixing points must be securely anchored with “fit for purpose” screws or dyna bolts.
- Fit the SP4 domed urinal grate to the left side outlet ensuring to seal and tighten. Complete all connections for the waste discharge and flushing device to the urinal. The flushing device should then be tested multiple times and all connections checked for leaks.
- Ensure enough water is being flushed to cover the urinal wall and is draining correctly. Make any adjustments to the flushing device for volume, flow rate or pressure as needed and in accordance with manufactures recommendations.
- On the completion the perimeter of the urinal should then be sealed with an appropriate non-pickable sealer.
- Clean the urinal as needed for handover, following the cleaning instructions provided.

Front View - UR4

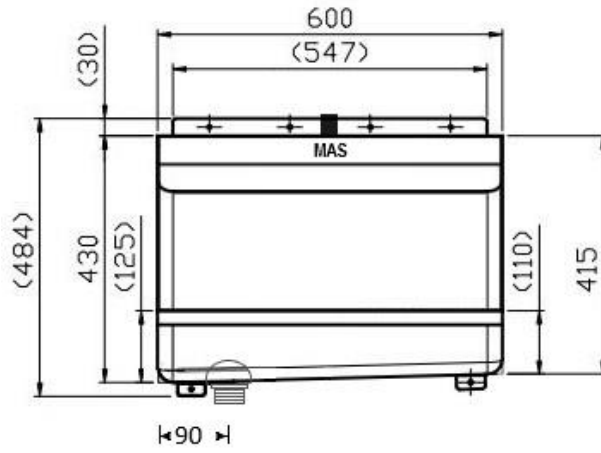

Rear View - UR4

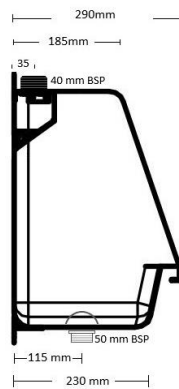
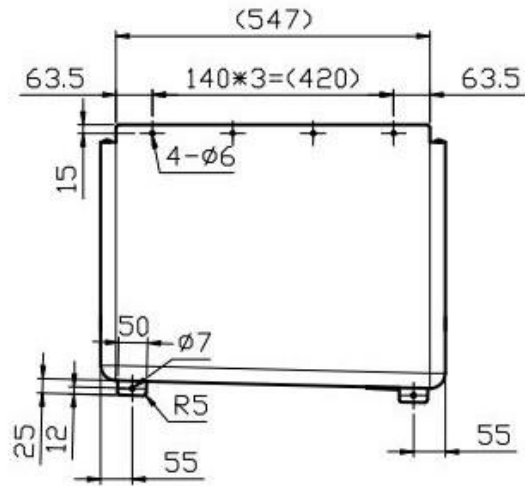

Front View - UR2

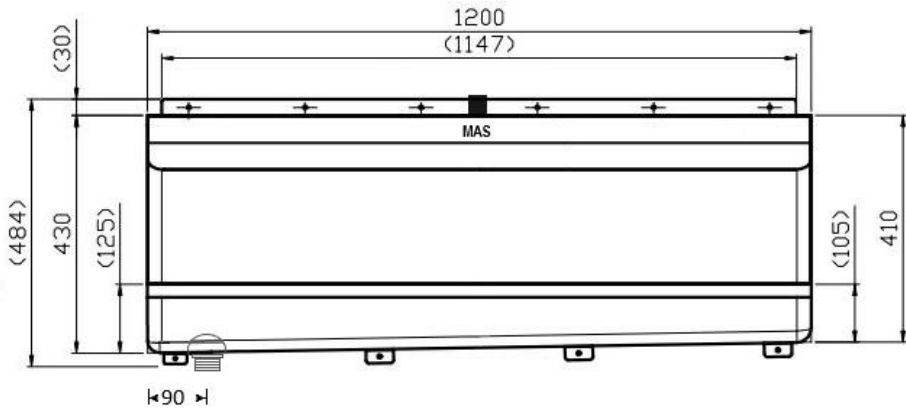

Rear View - UR2

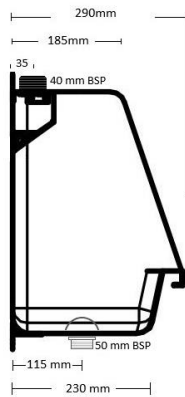
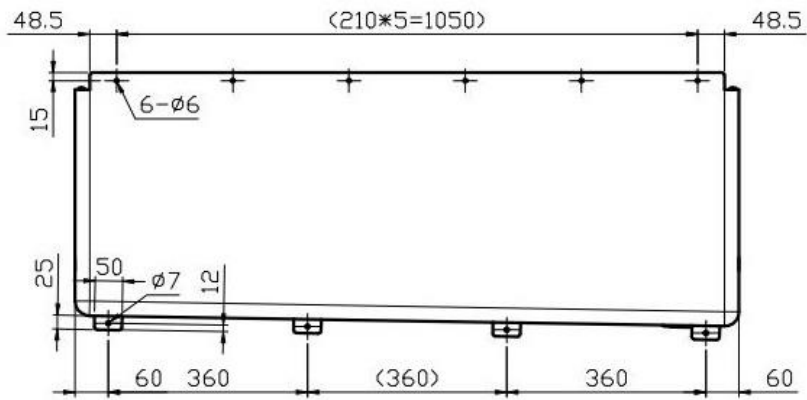

Front View - UR5

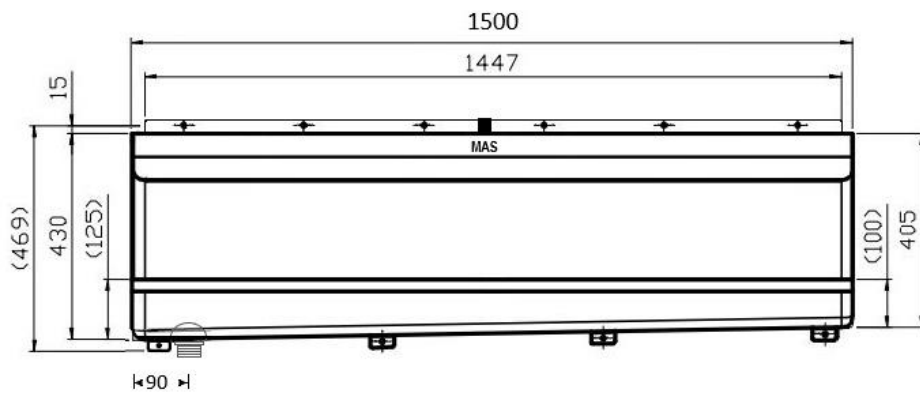

Rear View - UR5

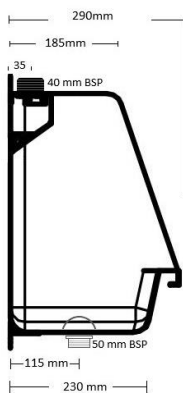
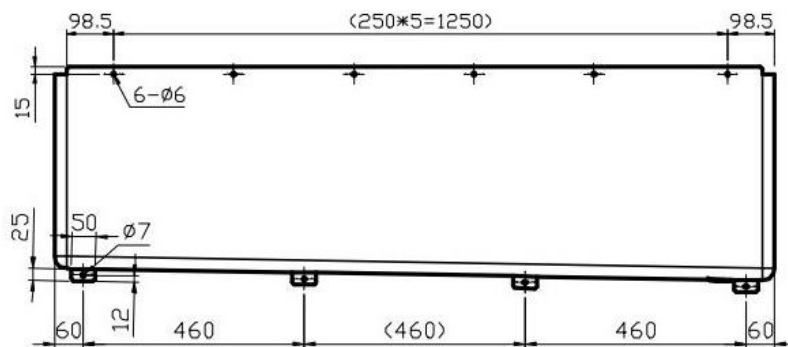

Front View - UR3

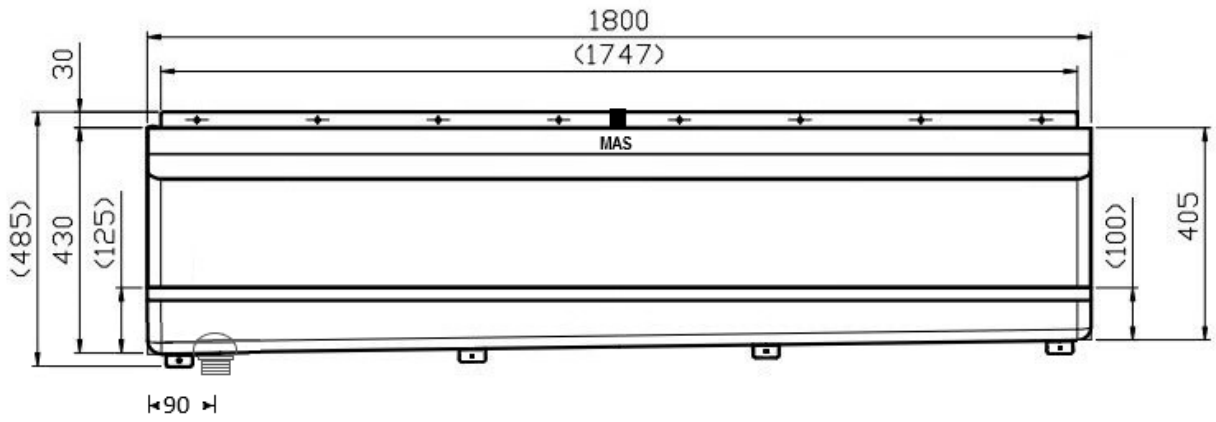

Rear View - UR3

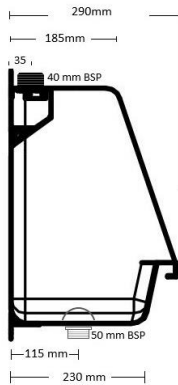
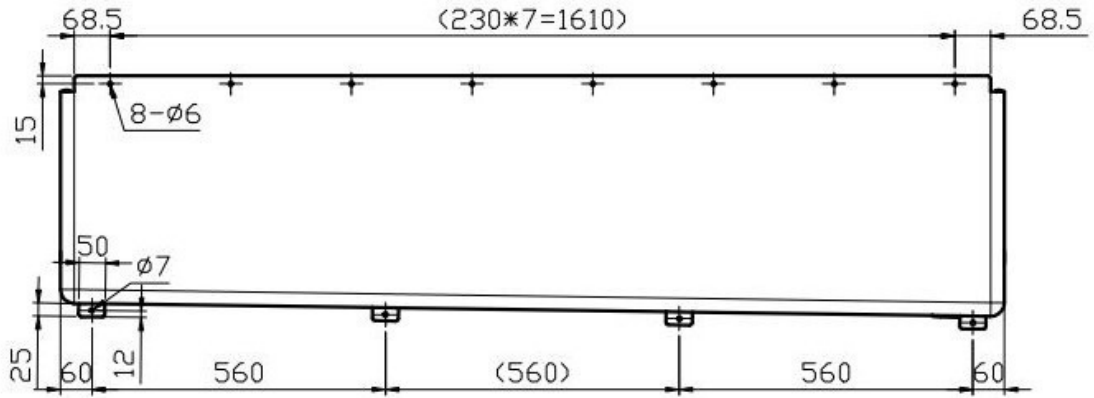

Front View - UR6

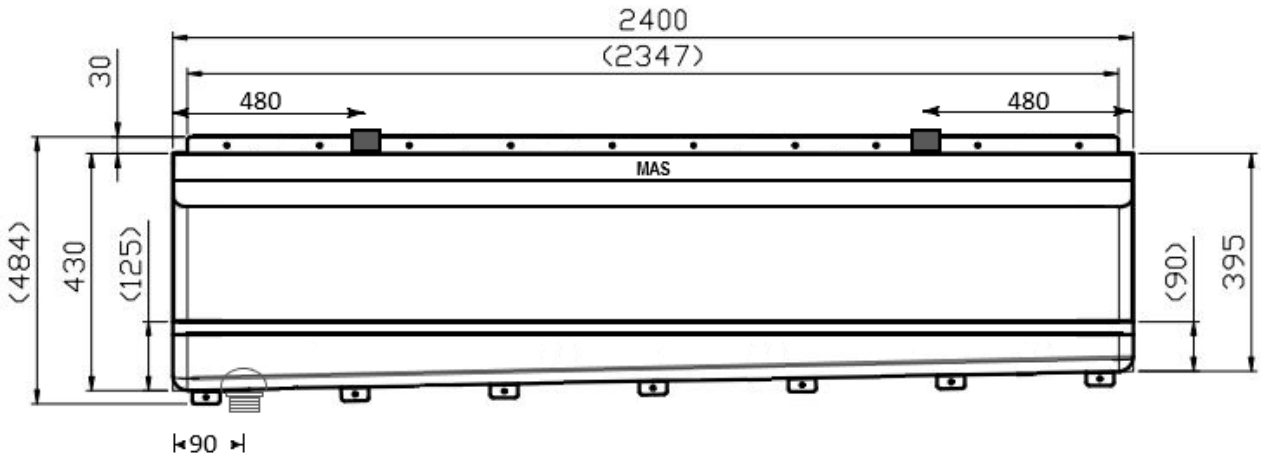

Rear View - UR6

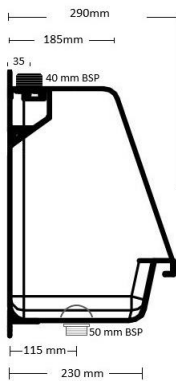
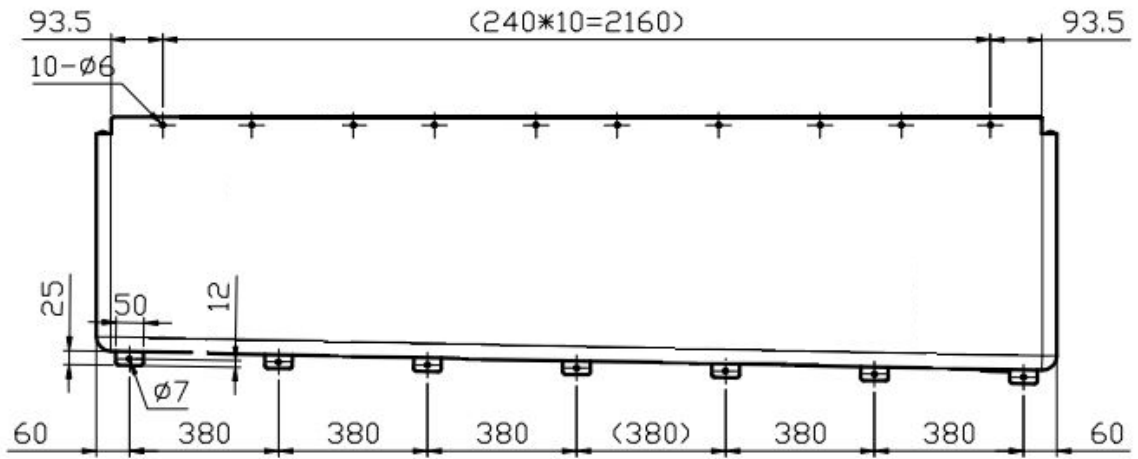

Caring for your Stainless Steel product

Your MAS urinal is made from quality type 304 stainless steel. With proper care and maintenance your urinal will give you many years of service.

Following these simple tips and cleaning routines will ensure the long life of your MAS stainless steel urinal.

Weekly Care

Preventative maintenance is important to maintain the finish of your stainless steel. To thoroughly clean your stainless, use a non-abrasive stainless steel cleaner (available from your local supermarket or hardware) and follow the directions on the product being sure to cover the entire surface completely, rinse thoroughly and dry with a soft cloth.

Stains and Rust

By its very nature stainless steel is resistant to rust. A build up of iron particles from external sources, heavy use or water supply commonly causes rust on the surface of the stainless steel. The quality of your water supply can also often cause stains to appear on your stainless. Both rust spots and staining can be removed with a thorough clean (see Weekly cleaning).

Scratches

Scratches are inevitable with all stainless steel products. With regular use the scratches will blend together and form a uniform finish. The appearance of these scratches can be reduced by the use of a fine 3M Scotch Brite pad; wipe along the grain of the entire area and rinse thoroughly (rubbing across the grain will dull the finish and introduce more scratches).

What to avoid

Avoid Chlorides are very aggressive to stainless steel. These are commonly found in detergents, soaps, bleaches and drain cleaners. Thoroughly rinse your sink after using one of these products to avoid surface pitting.

Avoid steel wool to clean your stainless steel. It will leave behind steel fragments that will cause rust spots.



Warranty Conditions

For full warranty please visit masales.com.au

MAS® is a registered trademark of Mark Anderson Sales Pty Ltd

The information contained on this sheet is to be read in conjunction with any other warranty, installation or care information provided to you by Mark Anderson Sales located at Building 4 84 Ingleston Road Wakerley QLD 4154.

Our goods are supplied with guarantees that cannot be excluded under Australian Consumer Law.

Conditions

All stainless-steel products manufactured by MAS for commercial applications are covered by a 12-month manufacturer's warranty from date of installation or 24-months from date of invoice whichever occurs first. If a product is on-sold by another party other than MAS the seller has no authority to offer additional warranties on behalf of MAS or any other MAS products.

All supplied products must be installed by a qualified and licensed contractor in accordance with the plumbing code of Australia and installed to the appropriate standards in conjunction with local state or territory requirements.

Components such as valves, pressure limiting valves, temperature mixing valves and flexible hoses supplied with an MAS assembled product are covered by the suppliers (manufacturer) warranty. Any extension of warranty terms offered by third parties will be the responsibility of those companies

Claims made under warranty conditions must be made within a reasonable period of the discovery of a defect.

Visual imperfections or defects that are ignored at the time of install will be excluded from all warranty conditions and all warranty responsibilities will be forfeited.

MAS will repair or replace at our discretion any product part which is proven to be defective through faulty materials or workmanship within the warranty period. Repair or replacement of a product under the terms of this warranty does not give rise to an extension of original warranty period.

Where a product is installed outside the boundaries of a metropolitan area, the cost of any transport or travelling shall be the responsibility of the claimant.

Liability outside of statutory requirements is limited to the purchase price paid for the product or to the repair or replacement of the product. Any other loss directly or indirectly due to malfunction of the product is excluded from the warranty.

Standard Exclusions

- Normal wear and tear
- Accidental or malicious damage
- Third party product causing failure
- Incorrect or not fit for purpose installation
- Any unauthorized alteration, modification or substitution
- Failure due to excessive or insufficient water supply
- Failure from foreign matter from installation or water supply
- Any and all consequential loss or damage, directly or indirectly caused by malfunction
- Acts of God

