

# WATERSAVING URINAL

## FEATURES;

- Waterless Waste Outlet.
- Vandal Resistant Design.
- Supplied with Automated Periodic 'AutoClean' Device.
- Manufactured to Custom Lengths (up to 1200mm Long).
- Available in Modules for Joining on Site.
- Perfect for schools, clubs and public amenities.



# BRITTEX

The **Britex Watersaving Urinal** is a great, vandal resistant water saving fixture that incorporates the unique 'Britex Waterless' outlet requiring no costly replaceable cartridge, bio block or sealant fluid. Instead the Britex Waterless outlet utilises a self-sealing one way diaphragm that allows urine to pass, whilst trapping odours within the plumbing. To assist with the regular maintenance regime, each Watersaving urinal is supplied with a Britex Hygiene Clean Device (see pg. 19) that periodically triggers a cleaning cycle to ensure the connected plumbing is flushed and the unit itself is kept clean.



WaterMark  
ATS 5200-489/2005  
Lic. WMKT20100

PRODUCT CODE:

## UESI-LF

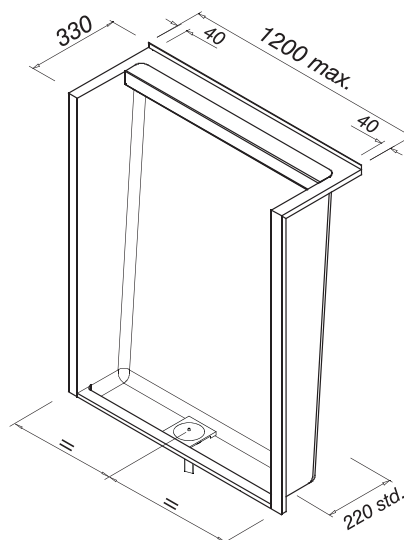
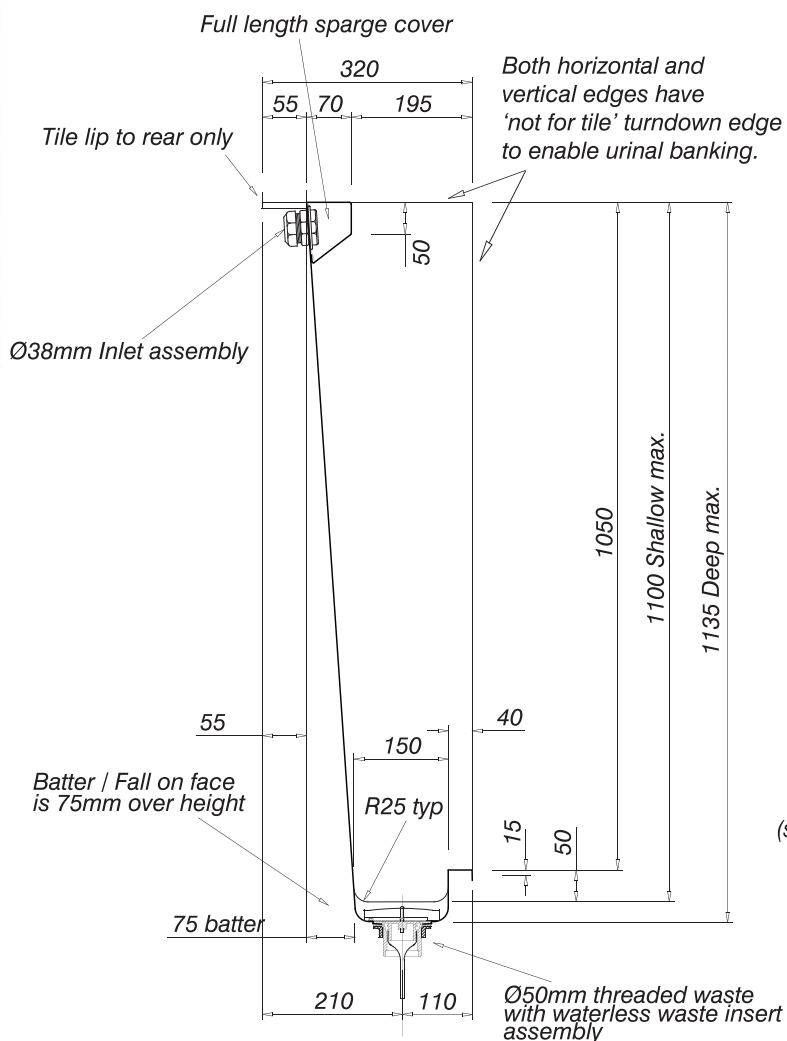

(standard waste position is centre from either end & 220mm from rear wall)

SECTION; WATERSAVING URINAL  
WASTE POSITION; STANDARD  
(Rear entry shown)

## SPECIFICATIONS

When specifying this product, please include the following details;

- Product **Name** and **Model No.**
- Product **Length** (1200mm MAX per unit)

## OPTIONS

- **Multiple Modules.**
- Top or rear **Water Entry.**

**Melbourne**

Britex Place, Mirra Court  
Bundoora  
Victoria 3083  
Telephone 1300 764 744  
Fax (03) 9466 9044

**Sydney**

Unit 11, 16-18 Northumberland Rd  
Taren Point  
New South Wales 2229  
Telephone 1300 764 744  
Fax (02) 9531 2800



Quality  
ISO 9001

**BRITEX**

STAINLESS STEEL FABRICATED PRODUCTS

[www.britex.com.au](http://www.britex.com.au)

e-mail [info@britex.com.au](mailto:info@britex.com.au)

A.B.N. 83 004 309 737

SINCE  
1938

Represented in all states of Australia, throughout Asia and the Pacific Regions.

All product manufacturing by **BRITEX** can be adapted to suit your special application.

Allow 5mm tolerance for setout dimensions given in these drawings. Details accurate at time of print.

As **BRITEX** is always committed to improving on design and quality, it is possible that some details may alter without notice.