

ZH-6140XL

HYDRAULIC CONCEALED FLUSH VALVE

Dimensional Data (mm) are Subject to Manufacturing Tolerances and Change Without Notice

ENGINEERING SPECIFICATION

- Suits back entry slab type urinals
- One flush valve required for every 1.8 metres of urinal length to AS 3500.1.2.1995 Table 9.2
- Min water supply pressure - 175kPa
- Max water supply pressure - 500kPa
- Flush volume - 2L
- Flow rate required - 1.5L per sec
- Inlet connection - 25mm BSP

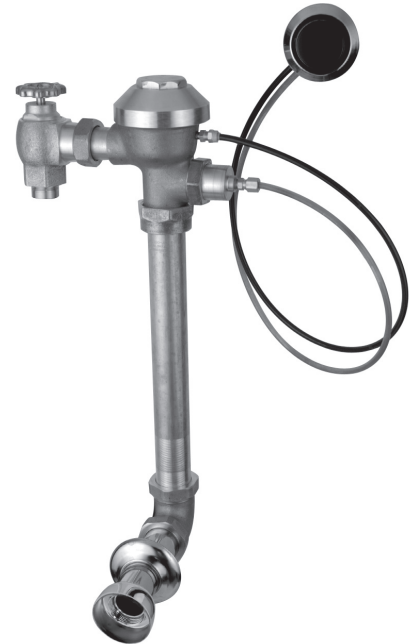

STANDARDS COMPLIANCE

- Watermarked Approved - WM-000307

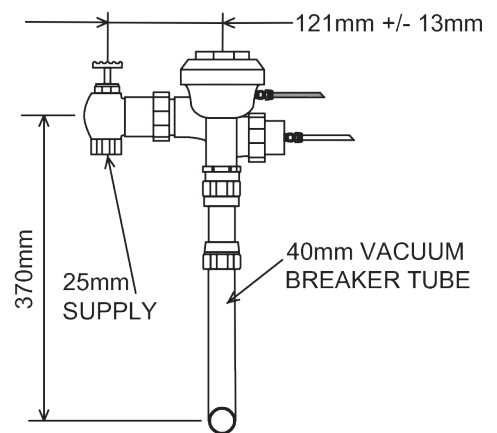
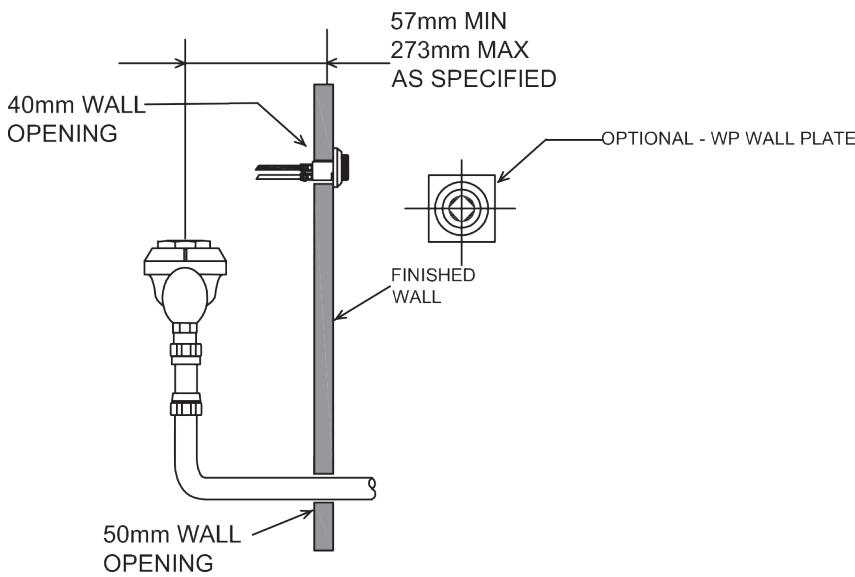

OPTIONS

CODE	DESCRIPTION
ZDF-6152BX12	300x300mm stainless steel panel and frame
SS-300H18	300x300mm stainless steel panel w/ 18mm centre hole
SSP-300	300x300mm stainless steel panel and frame w/ concealed fixings