

## ZH-6195XL HYDRAULIC CONCEALED FLUSH VALVE

Dimensional Data (mm) are Subject to Manufacturing Tolerances and Change Without Notice

### ENGINEERING SPECIFICATION

- Suits wall hung single urinals
- Optimum pressure for certain brands of open rim urinals is 250kPa, achieved by Wilkins #600 or NR3 series.
- Min water supply pressure - 175kPa
- Max water supply pressure - 350kPa
- Flush volume - 5.5L
- Flow rate required - 1.5L per sec



### STANDARDS COMPLIANCE

- WELS – 3 Star – 1.5L
- Watermarked Approved - WM-000307

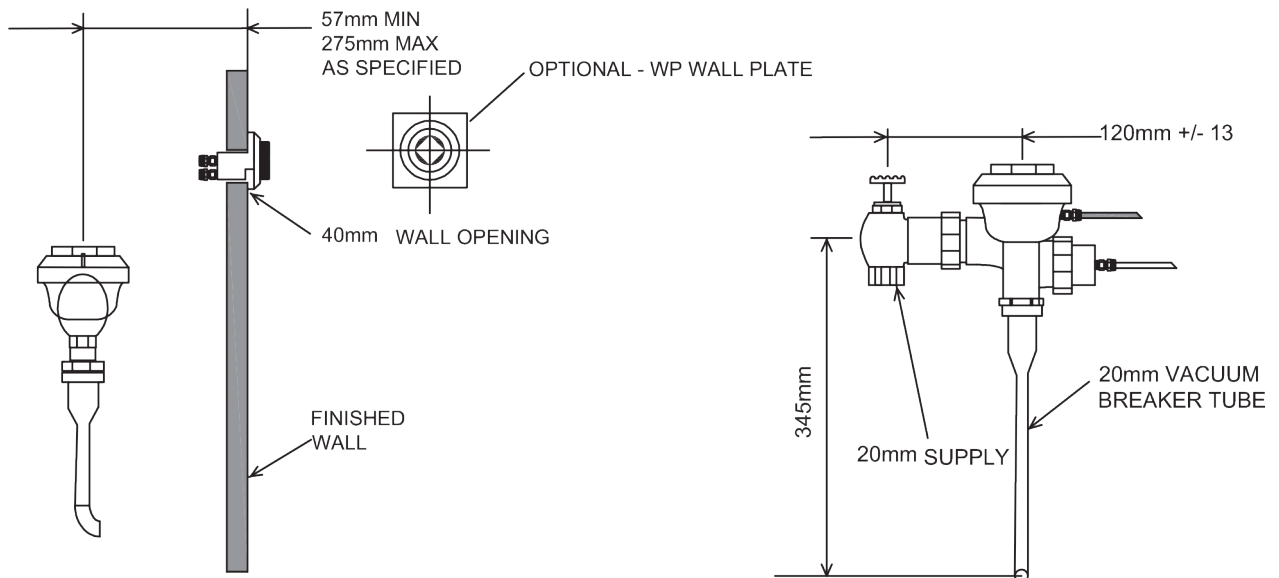

### OPTIONS

CODE	DESCRIPTION
ZH-6152BX12	300x300mm stainless steel panel and frame
SS-300H18	300x300mm stainless steel panel w/ 18mm centre hole
SSP-300	300x300mm stainless steel panel and frame w/ concealed fixings